



Suggestions for the Design and Development of Smart Home Control and Management Systems

* Abdurrahman Yusuf Abdullahi ¹, Abubakar Surajo Imam ², Abdulkadir Shehu Bari ³, Muhammad Abubakar Falalu ⁴, Amina Ibrahim ⁵, Muhammad Ahamd Baballe ⁶

¹ Department of Electrical Engineering, Kano University of Science and Technology Wudil, Kano State, Nigeria.

³ Department of Artificial Intelligence, School of Computing, Audu Bako College of Agriculture Dambatta, Kano, Nigeria.

⁴ Dept. of Networking and Cloud Computing, School of Computing, Audu Bako College of Agriculture Dambatta, Kano, Nigeria.

⁵ Department of Computer Science, School of Technology, Kano State Polytechnic, Nigeria.

^{2,6} Department of Mechatronics Engineering, Nigerian Defence Academy Kaduna, Nigeria.

Corresponding author: Abdurrahman Yusuf Abdullahi

Department of Electrical Engineering, Kano University of Science and Technology Wudil, Kano State, Nigeria.

Received Date: 28 Jan. 2026

Published Date: 24 March 2026

Abstract

DC batteries power the smart home and management system in this study. When fully charged, it can run for two to three days before the battery runs out. When the device is turned on, the LCD displays the greatest temperature as well as the research title. It will also indicate that the house is unoccupied. As soon as you press the push button to enter the house, a welcome message will appear on the Liquid Crystal Display (LCD), and the number of individuals inside will increase proportionately to the number of people who arrive. It is up to you how many people you want inside the house. The door will stay closed until someone pushes the exit button and leaves the house, allowing another person to enter, if you set the maximum number of guests to 12. The house has a fan that is used to decrease the temperature if it gets too hot. You may set the maximum temperature for when you want the fan to start up automatically. The fan won't start up until the temperature reaches 30°C if you choose that as the maximum. Additionally, the fan and light will automatically turn off if everyone leaves the house because no one is inside. For security purposes, there is a light in front of the house. It will automatically turn on at night if it is dark. The second LDR outside the home controls this light. For security reasons, the lightbulb outside the house will turn off during the day if the LDR detects light, and it will turn on itself at night if it detects darkness. Inside the house is the first LDR. It will turn on the lights in the house if someone enters. The light will not go off until everyone leaves the house. In this research we have discussed the future directions and recommendations one needs to take to have a smooth and successful design and implementation of a smart home and management system using modern technologies and sensors.

Keywords: Recommendations, Future Directions, LCD, Smart House, Sensor, Microcontroller.

I. INTRODUCTION:

As technology has advanced over the past century, the terms "smart home" and "intelligent security system" have emerged and are starting to attract the attention of researchers. A smart home is one that has the ability to control its appliances and gadgets remotely or automatically. Numerous sensors, modules, shields, and microcontroller boards can be utilized to create smart home systems [1]–[8]. As a result, this technology has many more characteristics, including temperature management, intelligent lighting arrangements, smart security, home facility protection, and many more, as illustrated in Fig. 1. A smart home also includes subsystems for wireless communication, entertainment, security, convenience, and information management [9]–[13]. A "smart home" is a system of linked sensors, actuators, interaction tools, and modules that offers homeowners applications and support like automation, entertainment media, safety and security, and energy control with little to no human involvement. However, a number of factors, such as people's inclination to feel safe in their

own homes and the desire to reduce a high crime rate, make smart home safety and security systems extremely important and continually needed [14]–[16]. Numerous sensor types can be used in the construction of smart homes to safeguard them against combustion, as gas infiltration is another unwanted situation. Liquefied petroleum gas (LPG) is a popular cooking fuel in contrast. Since LPG is sold in cylinders, a leak might cause an explosion. A gas infiltration case is usually unknown to the occupants of the residences and other institutions. They might consequently ignite a conflagration that bursts. To avoid this dangerous situation, the gas leakage detection strategy must be installed and used [51–53]. There has been a significant rise in crime recently [54]. As a result, installing protection systems in homes is crucial [17,18]. The use of different types of sensors, such as PIR sensors, water level sensors, soil moisture sensors, light intensity sensors, current sensors, voltage sensors, DC motors, and ultrasonic sensors, has been discussed extensively by many other researchers [55]. To build a complete smart home system, all of the sensors stated above can be incorporated with modules and microcontrollers [10]–[22]. The research's contribution might be summed up as the introduction of a low-cost system for managing applications for smart home gadgets. The suggested system has a few crucial functional components. The first is used for security, and the second is used for the occupants' safety in the residence. The IR sensor, laser beam directed at a Light Dependent Resistance (LDR) sensor, Bluetooth module with programmed smart phone App, and servo motor make up the first component. The gas sensor, flame sensor, temperature and humidity sensors, liquid crystal display, and alarm make up the second component. The Arduino served as the processing engine for the sensor data in both components [56].

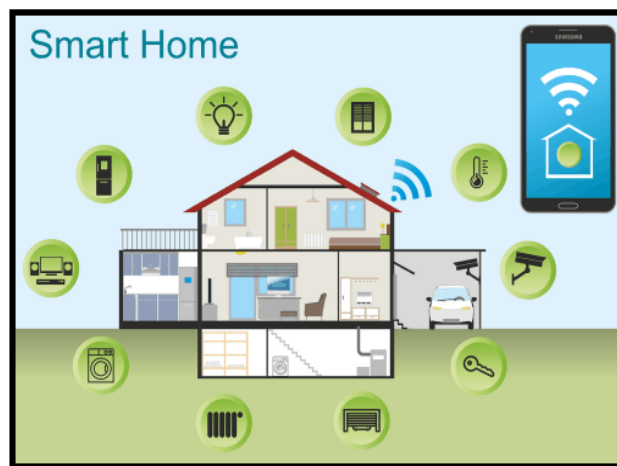

Fig. 1. A simple smart home

II. SUGGESTIONS FOR THE DESIGN AND DEVELOPMENT OF SMART HOME CONTROL AND MANAGEMENT SYSTEMS

The following suggestions should be taken into account while creating a smart home control and management system:

- i. Select the Proper Actuators and Sensors: Choose the right sensors and actuators to precisely monitor and regulate the temperature, humidity, and security of the home.
- ii. Optimize Connectivity: For smooth device connection, make sure there are reliable connectivity alternatives including Wi-Fi, Zigbee, and BLE.
- iii. Create User-Friendly Interfaces: Design user-friendly interfaces that make it simple for homeowners to manage and keep an eye on their living space.
- iv. Implement IoT and Automation: To improve the smart home's functionality and efficiency, integrate IoT technology and automation systems.
- v. Emphasis on Energy Management: Create systems, including smart energy management systems, that maximize energy use and minimize waste.
- vi. Think about Security and Safety: Make sure the system has strong security measures to guard against threats and unwanted access.
- vii. Use Real-Time Data: To give prompt feedback and insights into the home environment, use real-time data gathering and analysis.
- viii. Plan for Scalability: Create systems that can grow to support more features and devices as needed.

You may build a smart home control and management system that improves security, comfort, and energy efficiency while offering a smooth user experience by adhering to these suggestions.

III. SMART HOME

From fire vaults to warm cells to torches and candles, and finally to the arrival of the most contemporary invention, namely electricity, homes have been created throughout antiquity, which has offered convenience for the home's occupants. After that, it was explored how to use embedded systems and electronic parts in machinery and other appliances. While programming instructions for the CPU of embedded systems can be used to complete a number of functions, such automatic hot and cold washing, turning on/off lights [57], and security employment. Since the 1970s, embedded and integrated

systems have gained popularity and started to appear in urban households' domestic operations. In order to find necessary smart home systems, home automation is able to link between electrical and electronic features [23], [24]. Here are a few examples of smart home automation and control applications [25-32].

1. Keeping an eye on the weather and controlling the heating or cooling system.
2. Identifying a leak in the cooking gas and advising the residents of the house via an alarm and an SMS.
3. Keeping an eye on the weather and, in case of rain, closing the windows of the house.
4. The clever control that determines whether to switch on or off the exterior lighting for the house depending on the time of day or night.
5. The intelligent control of turning ON/OFF various home appliances via a mobile phone using Wi-Fi, Bluetooth, or an SMS service.
6. Utilizing RFID [58, 59] technology to unlock and close the front door of the house rather than traditional locks.
7. Utilizing movement detection sensors to protect a house against burglary [60].
8. When the fire first appears, turn on the firefighting pumps.
9. Using intelligent irrigation to water the garden based on the amount of humidity in the soil.
10. Electricity for the home is produced using solar cells [61, 62].

The items previously mentioned all offer residents of homes security and safety. The aforementioned applications can also be used by businesses and other entities. While each of these applications makes use of a variety of electronic sensors, their data may be managed and processed by using a variety of microcontroller boards, including Arduino, Raspberry Pi, PIC microcontroller, and others. Due to its simplicity of use, low cost, and open-source nature for both software and hardware, the Arduino is therefore more frequently used than other varieties. The "Internet of Things" (IoT) [63] concept has been rapidly developing in recent years, and more amateurs and researchers are using this technology to develop smart home applications. The user handles these appliances remotely and sends or receives all necessary data through the system's mainboard through the internet by combining all of the home programmable equipment into a Local Area Network (LAN). Smart home sensors and modules can be wirelessly connected via a number of other technologies, including wireless LAN, ZigBee, Bluetooth, etc. Figure 2 shows an illustration of wireless communication between modules, sensors, and the internet in a home [33, 34].

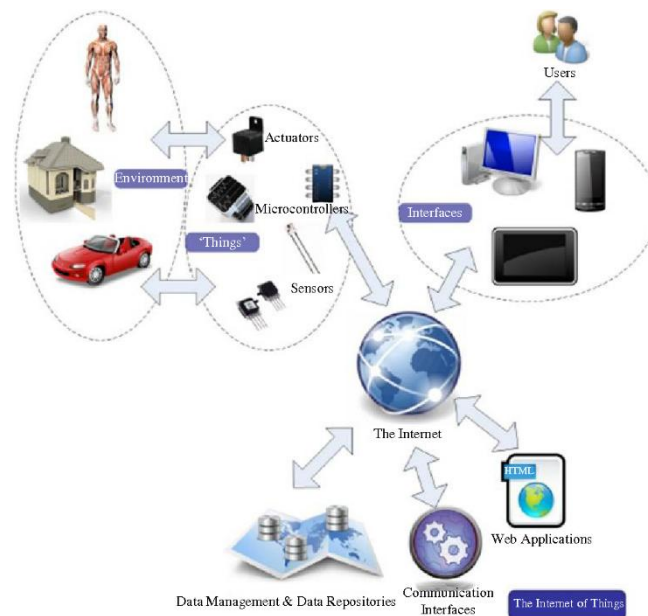

Fig. 2. Wireless communication between the modules and internet

A. Benefit from smart homes.

Smart home adoption has a number of noteworthy benefits that can be realized. Some of these benefits can be combined with the ensuing arguments [35–42].

1. From one location, manage and control all of your home appliances.
2. It gives users the option to add or remove new appliances from the system as needed.
3. Improve the security of the house's defense [64–67].
4. Through the use of a remote control, it offers the homeowners comfort for their house operations.
5. Savings on energy because only real consumption is used.
6. Increasing the equipment's usefulness, but smart homes might enable even more effective appliance operation.

B. System for securing a home

Home security is not a recent development; it has been acknowledged since the Stone Age. People then used a variety of rocks, trees, and weapons to ward off predators [68]. The methods for safeguarding one's royalty have been progressively improved in recent years. Nowadays, people utilize considerably more sophisticated, safe, and affordable security measures to guarantee the ideal property's security. To ensure effective protection for homes against burglary, the automatic home security system is built on various electrical components or makes use of microcontroller boards [43, 44].

IV. SYSTEM DESIGN AND CONSTRUCTION

The newly launched system typically consists of two major components. The first section relates to the safety of the house, while the second is reserved for automatic control (i.e., automation). The Arduino IDE is used to program both components, which are based on Arduino microcontrollers [45]. The infrared (IR) sensor and the laser beam that is pointed directly at the LDR serve as the foundation for the home's security system. The IR sensor immediately sends logic "1" to the Arduino Nano kit to turn ON the warning siren the instant the thief walks in front of it. Additionally, the thief will be facing the laser beam if it tries to avoid the IR sensor. When the ray is broken, the LDR resistance value increases, and the Arduino Nano then follows the previously described procedure. The ATmega328P of the Arduino Nano and Arduino Leonardo microcontrollers with multiple sensors, such as the MQ-02 gas sensor, KY-026 fire detection sensor, as well as soil wetness sensor, are the foundation for the automation and controlling process for the introduced configuration. Table I describes the functions of the aforementioned sensors that are used in this work.

Sensor	Task
Flame sensor	It serves as a tool for configuration detection. Arduino will activate the buzzer, the sprinkler represented by LED 1, and print a warning message on the LCD in the event of a fire.
Gas sensor	It is used in the home kitchen for LPG detection purposes. The Arduino will activate the buzzer and print warning messages on the LCD in the event of a gas leak.
DHT-11 sensor	Used to measure weather conditions such as temperature and moisture. The LCD will display the temperature and humidity values, and the LED-2-designated air conditioner will be turned on by the Arduino.
Soil moisture sensor	Used to measure the moisture content of soil. The Arduino will turn on the water pump, which is symbolized by LED-3, and print a message on the LCD if the soil is dry.

The system is also developed using the Arduino Leonardo, 2x16 LCD, and DHT-11 sensors; the LCD's purpose is to display the weather's temperature and humidity. Additionally, the LCD will display warning messages for the LPG leak and fire detection situations. Finally, the HC-05 module, which enables Bluetooth-based wireless communication with a unique Android app and a small servo motor, is also used to remotely control the garage door [69]. The employed Android application was created in the "MIT App Inventor" online environment, which was established by Google and is run by the Massachusetts Institute of Technology. This platform relies on the development of a graphical user interface based on a visual programming language (i.e., block arrangement), which enables users to drag and drop visual blocks to create the necessary software [46–50].

V. MATERIAL AND METHODS

4.1. Materials

Table II: Below are the materials used in this research

S/N	Names of components	Number used
1	LDRs	2
2	Lights	2
3	Liquid crystal display	1
4	Microcontroller	1
5	Buzzer	1
6	IR Sensor	1
7	Switch Button	1
8	Light Emitting Diode	1
9	Battery	3
10	Connections	29
11	Fan	1

4.2. Methods

The microcontroller PIC16F8877A serves as the brain of the research, which offers relay with necessary information when the temperature is very high above the setting point to activate the DC fan in order to prevent the battery from unnecessary discharge. In cooperation with the DHT11 temperature/humidity sensor, it is used to monitor the temperature level in the

premises while the LCD is used to display the corresponding temperature inside the room and also the number of people inside the house. Also, DC 12v bulbs are controlled by an LDR sensor during the day and night periods in order to control the waste of power consumption. The outside light is used at night for security reasons. However, the major components mentioned work in cooperation to form the system with the microcontroller. The automatic door, which is controlled or operated by the push buttons, is used to control the number of people who will enter and exit the house with the help of an IR sensor, which is used in the system.

4.2.1. Connection of the Microcontroller to LCD

The liquid crystal display pins are connected to the microcontroller, which is the brain of the whole research.

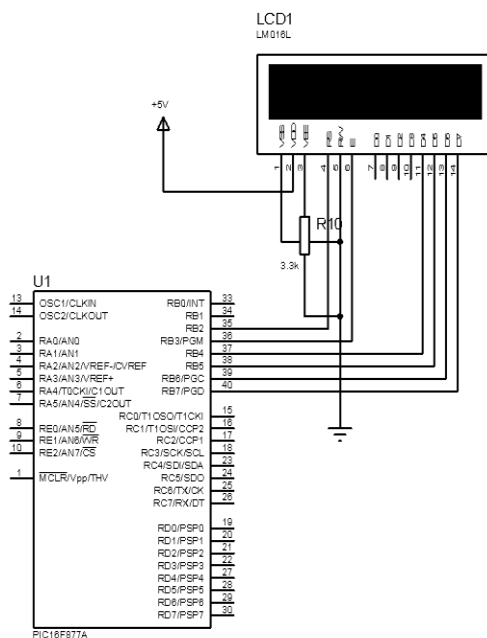

Fig. 3. LCD interfaced to PIC16F877A

4.2.2. DHT11 temperature/humidity sensor unit

The DHT11 acts as a temperature and humidity sensor. It gives an output of 10mV/C and is capable of producing a voltage from 10mV to 1.5V that corresponds to temperatures from 0 C to 50 C and 0-80%.

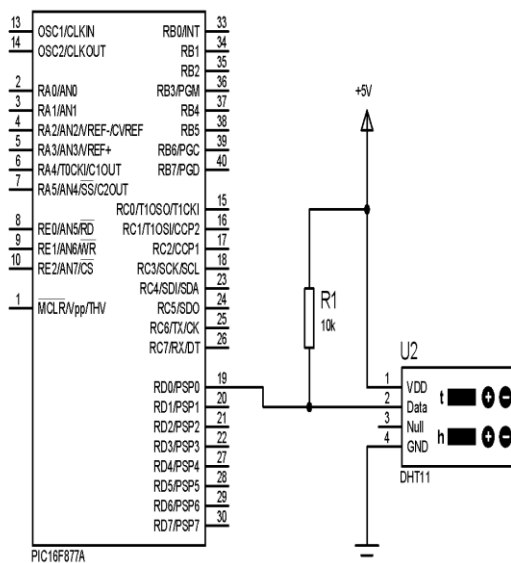

Fig. 4. Connection of DHT11 to microcontroller

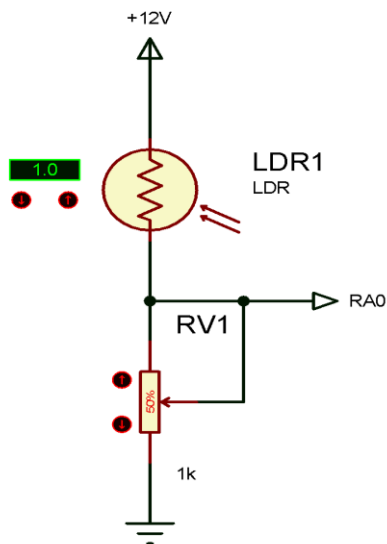

Fig. 5. Infrared Sensing Unit

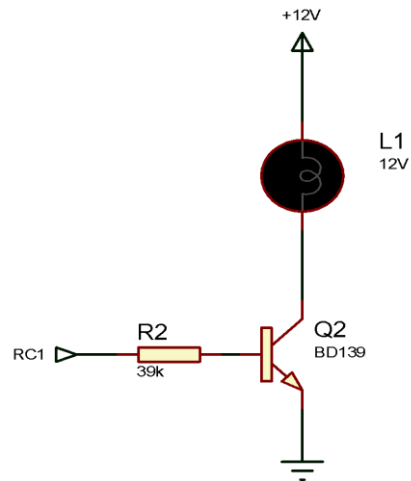

Fig. 6. DC fan/light transistor

4.2.2. DC FAN/LIGHT Control Unit

The unit serves to control the DC fan and light system using a BD139 transistor. The circuit of this unit is shown in the figure below.

4.2.4. Door control unit

The arrangement of the circuit as below is the actuator part, which uses the BC547 transistors to enable the actual door control to open and close due to movement of the motor clockwise and anticlockwise when a visitor arrives.

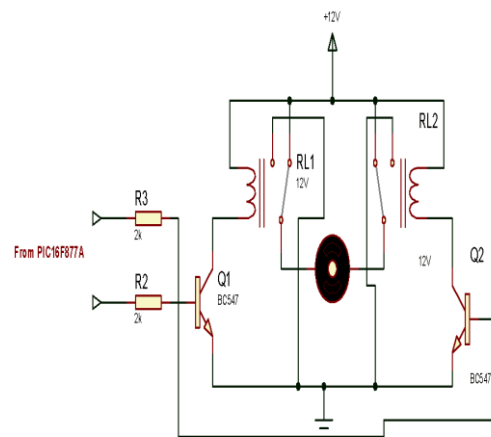
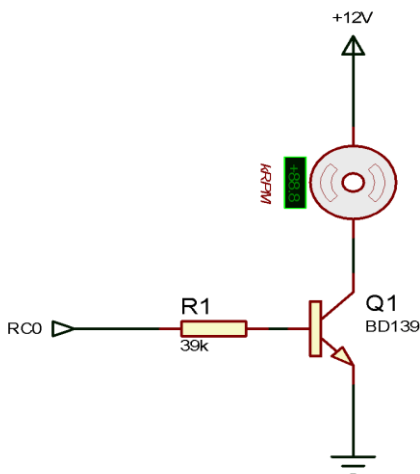

Fig. 7. Door control circuit

4.4.5. Alarming unit

This unit is used for alarming. When the limit is exceeded, it will sound an alarm showing that the number of people that are required to enter the house has reached its limit.

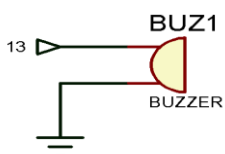

Fig. 8. Alarming unit

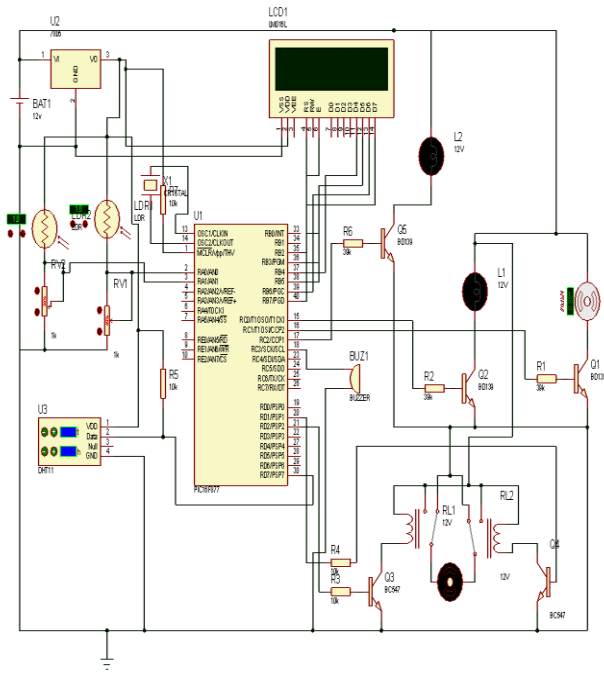

Fig. 9(a). Complete circuit diagram

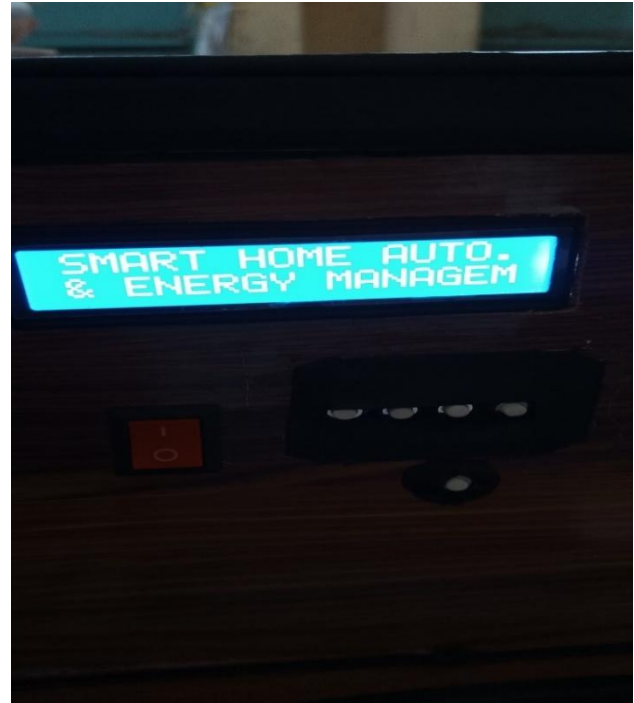

Fig. 10. Implementation of the Circuit Display the Title of the research



Fig. 9(b): Implementation of the System

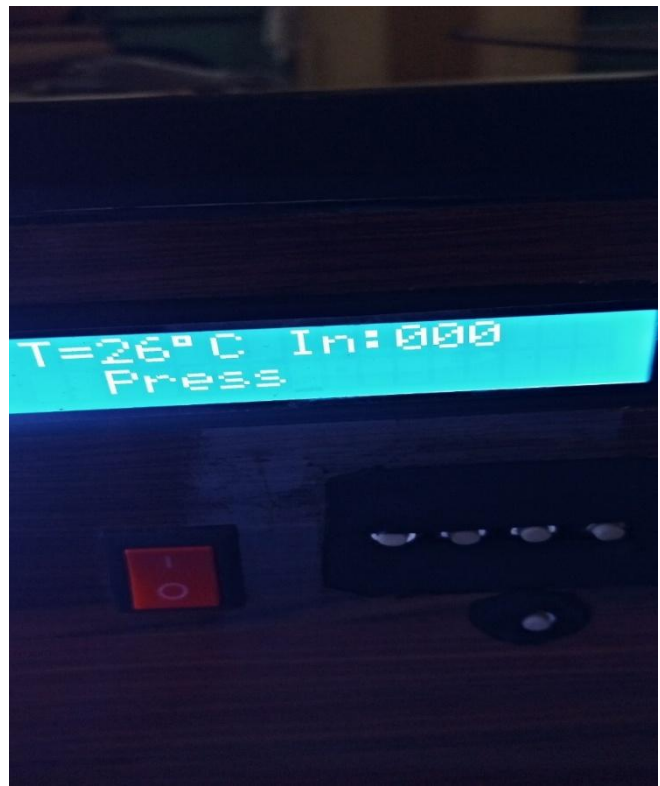

Fig. 11. The whole system implementation

VI. RESULTS

The images below are the pictures of the results obtained from the implemented system.

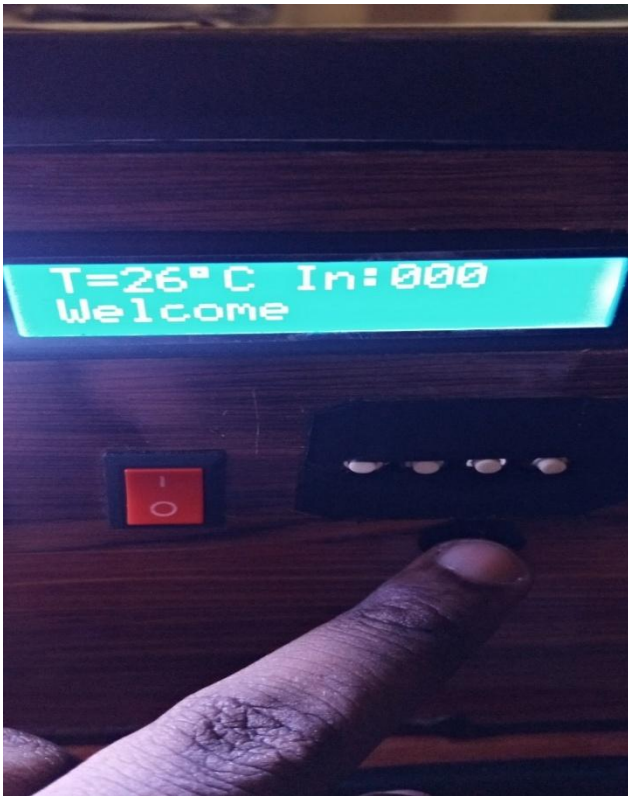

Fig. 12. Implemented Circuit Displaying the Process of Pressing the Entrance Door

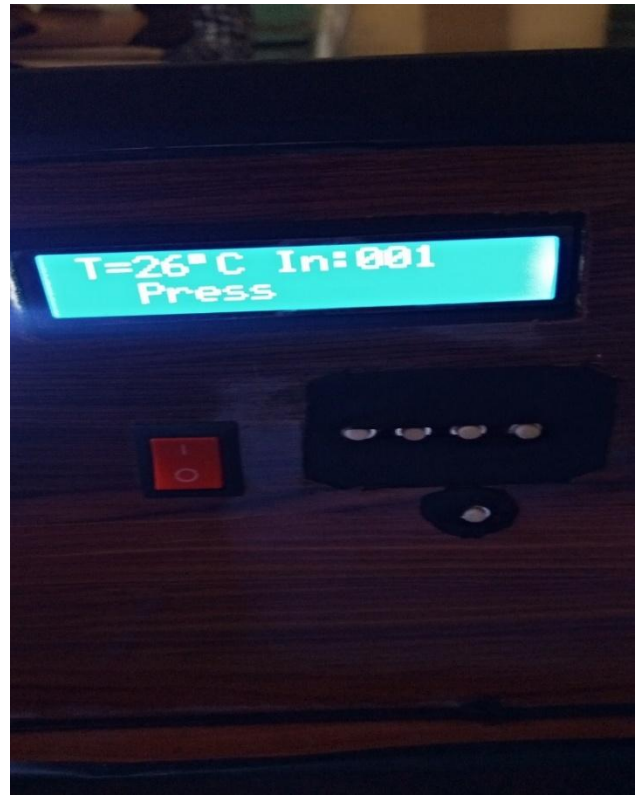

Fig. 14. System displaying one person is inside the house

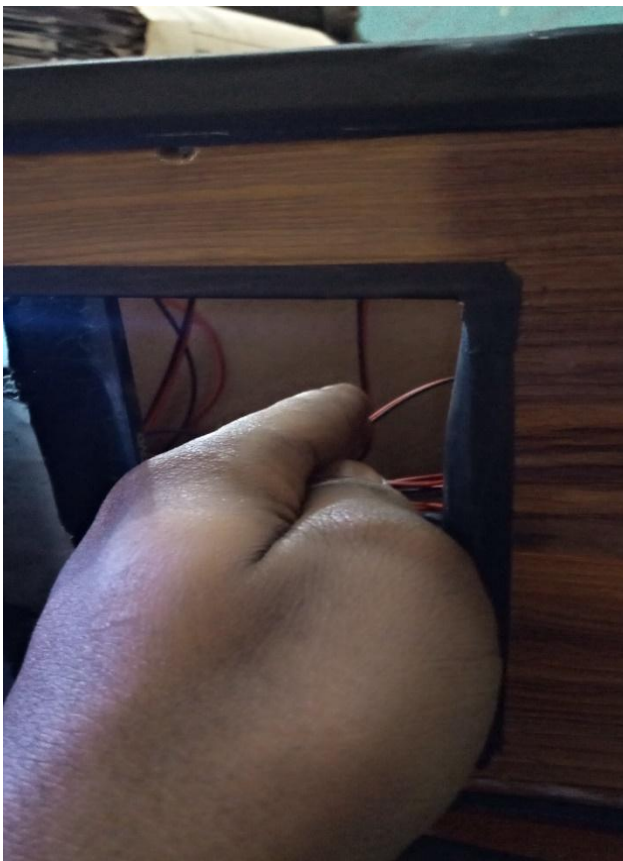

Fig. 13. The Process of entering the door

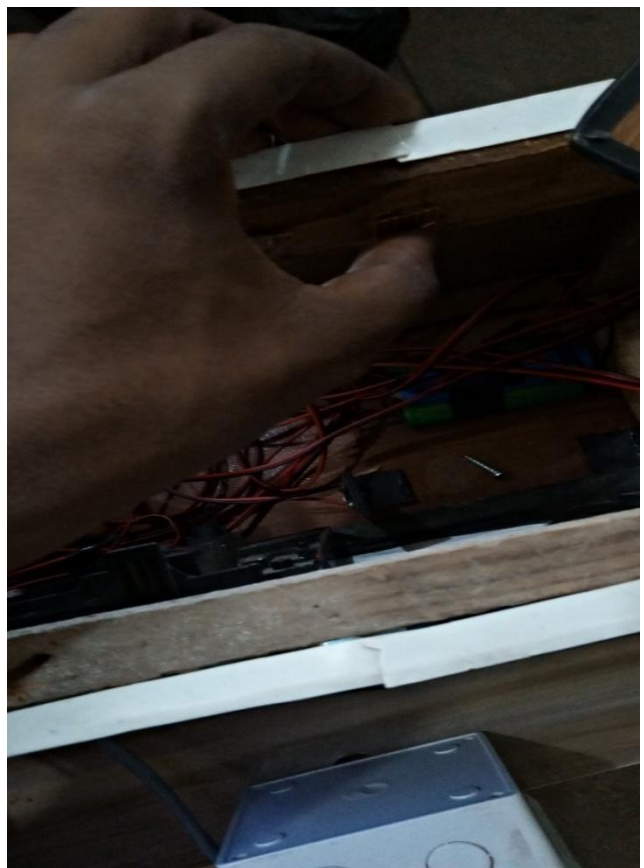

Fig. 15. The process of pressing exit button from the house



Fig. 16. The process of leaving the house through the door

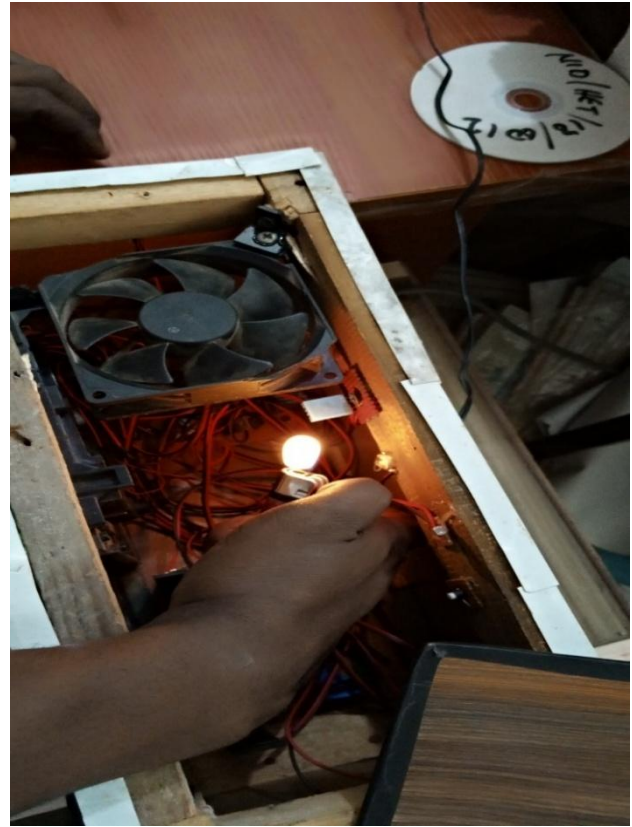

Fig. 18. The DHT-11 sensor is used to monitor the temperature and humidity of the house. If the temperature exceeds the maximum temperature set, the fan will turn on by itself with the help of the DHT-11 sensor.



Fig. 17. The outside LDR that is used to control the front light of the house will go off during day light. That is, if the research is exposed to light, the front light will not come on until it sees dark the LDR

CONCLUSION

One of the main tenets of the smart home is that it uses less energy, improves security, and makes tenants' lives more comfortable. This study looked at the planning and development of an inexpensive framework for smart home automation. In this study, research articles on inexpensive smart house designs utilizing the Arduino Nano and Arduino Leonardo microcontroller boards were examined. A smart gate door controller is intended to monitor household appliances in order to minimize electricity consumption [70], offer security, and regulate who can enter the house [72–78].

Future Directions

Future smart home systems will focus on greater integration, intelligence through AI, and enhanced security and privacy. Key future directions include more intuitive user interfaces, seamless device interoperability via technologies like 5G and IPv6, and AI-driven personalization to anticipate resident needs for improved convenience, safety, and energy efficiency [78].

Enhanced intelligence and automation

- i. **AI and machine learning:** Future systems will use AI to learn user habits and preferences, enabling them to proactively adjust settings for comfort and energy savings without direct commands.
- ii. **Predictive maintenance and health monitoring:** AI can analyze data from sensors to predict equipment failure or monitor residents' health, sending alerts for potential issues or emergencies.
- iii. **Advanced human-computer interaction:** Expect more natural and intuitive control methods like gesture recognition, voice commands, and systems that can sense the presence and state of residents through a variety of sensors.

Greater integration and interoperability

- i. **5G and IPv6:** Advanced network technologies are providing the foundation for a truly interconnected home where all devices can communicate seamlessly and reliably.
- ii. **Interoperable standards:** The future will see greater compatibility between different brands and devices, moving beyond proprietary systems to a more unified ecosystem.

Robust security and privacy

- i. **Advanced threat detection:** Systems will use AI and deep learning to detect potential threats and take appropriate security measures, ensuring occupant safety.
- ii. **Enhanced privacy controls:** As more data is collected, future development will focus on stronger encryption, user control over data, and transparent data usage policies to maintain user privacy.

Improved sustainability and efficiency

- i. **Energy management:** Smart homes will optimize energy use by learning inhabitant schedules and preferences, intelligently controlling lighting, heating, and cooling to reduce waste.
- ii. **Resource monitoring:** Systems will become more sophisticated in monitoring and managing other resources, such as water consumption [71]

REFERENCES

1. C. Hermanu, H. Maghfiroh, H. P. Santoso, Z. Arifin, and C. Harsito, "Dual mode system of smart home based on internet of things," *Journal of Robotics and Control (JRC)*, vol. 3, no. 1, pp. 26-31, 2022.
2. F. E. Aliabadi, K. Agbossou, S. Kelouwani, N. Henao, and S. S. Hosseini, "Coordination of smart home energy management systems in neighborhood areas: A systematic review," *IEEE Access*, vol. 9, pp. 36417-36443, 2021.
3. J. Wang, N. Spicher, J. M. Warneck, M. Haghi, J. Schwartz, and T. M. Deserno, "Unobtrusive health monitoring in private spaces: The smart home," *Sensors*, vol. 21, no. 3, pp. 864, 2021.
4. Z. Dong, X. Ji, G. Zhou, M. Gao and D. Qi, "Multimodal Neuromorphic Sensory-Processing System with Memristor Circuits for Smart Home Applications," in *IEEE Transactions on Industry Applications*, 2022.
5. A. Q. Badar and A. Anvari-Moghaddam, "Smart home energy management system—a review," *Advances in Building Energy Research*, vol. 16, no. 1, pp. 118-143, Augst 2022.
6. M. Jenal, A. N. Omar, M. A. A. Hisham, W. N. W. M. Noh, and Z. A. I. Razali, "Smart Home Controlling System," *Journal of Electronic Voltage and Application*, vol. 3, no. 1, pp. 92-104, July 2022.
7. M. A. Omeran, B. J. Hamza, and W. K. Saad, "The design and fulfillment of a Smart Home (SH) material powered by the IoT using the Blynk app," *Materials Today: Proceedings*, vol. 60, pp. 1199- 1212, April 2022.
8. N. Alsbou, N. M. Thirunilath and I. Ali, "Smart Home Automation IoT System for Disabled and Elderly," 2022 IEEE International IOT, Electronics and Mechatronics Conference (IEMTRONICS), 2022, pp. 1-5.
9. Q. I. Sarhan, "Systematic survey on smart home safety and security systems using the Arduino platform," *IEEE Access*, vol. 8, pp. 128362-128384, 2020.
10. A. L. G. K. Mishra and M. N., "Smart Integration of Home Automation and Uninterruptible Power Supply for Low Power Household Appliances," 2021 3rd International Conference on Advances in Computing, Communication Control and Networking (ICAC3N), 2021, pp. 799-803.
11. A. Zielonka, M. Woźniak, S. Garg, G. Kaddoum, M. J. Piran and G. Muhammad. "Smart Homes: How Much Will They Support Us? A Research on Recent Trends and Advances," *IEEE Access*, vol. 9, pp. 26388-26419, Jan 2021.
12. M. Humayun, M. S. Alsaqer, and N. Jhanjhi, "Energy Optimization for Smart Cities Using IoT," *Applied Artificial Intelligence*, vol. 36, no. 1, pp. 1-17, Feb 2022.

13. A. Ramkumar, T. Vaigaiselvam, S. Rajendran, S. Saravanel, A. Kamalesh and K. Rajesh, "Android Controlled Smart Home Automation with Security System," 2022 2nd International Conference on Advance Computing and Innovative Technologies in Engineering (ICACITE), 2022, pp. 1245-1249.
14. R. M. Sari, E. Sabna, R. Wahyuni, and Y. Irawan, "Implementation of Open and Close a Housing Gate Portal Using RFID Card", *Journal of Robotics and Control (JRC)*, vol. 2, no. 5, pp. 363-367, 2021.
15. A. R. F. Shafana and A. Aridharshan, "Android based automation and security system for smart homes," *International Journal of Computer Science and Information Technology Research*, vol. 5, no. 3, pp. 26- 30, 2017.
16. H. M. Marhoon, M. I. Mahdi, E. D. Hussein, and A. R. Ibrahim, "Designing and implementing applications of smart home appliances," *Modern Applied Science*, vol. 12, no. 12, pp. 8-17, 2018.
17. U. Rahmalisa, A. Febriani, and Y. Irawan, "Detector leakage gas lpg based on telegram notification using wemos D1 and Mq-6 sensor," *Journal of Robotics and Control (JRC)*, vol. 2, no. 4, pp. 287-291, 2021.
18. H. Saad, S. A. Siddiqui, N. F. Naim and N. Othman, "Development of LPG Leakage Simulation System Integrated with the Internet of Things (IoT)," 2022 IEEE 18th International Colloquium on Signal Processing & Applications (CSPA), 2022, pp. 161-166.
19. Y. Praselia, A. G. Putrada, and A. Rakhmatsyah, "Evaluation of IoTBased Grow Light Automation on Hydroponic Plant Growth," *Jurnal Ilmiah Teknik Elektro Komputer dan Informatika*, vol. 7, no. 2, pp. 314–325, Sep. 2021, doi: 10.26555/JITEKI.V7I2.21424.
20. H. M. Marhoon and I. A. Taha, "Design and implementation of intelligent circuit breaker for electrical current sensing and monitoring," *International Journal of Core Engineering & Management (IJCEM)*, vol. 11, no. 4, pp. 39-50, 2018.
21. E. S. Rahayu, A. Ma'arif, and A. Çakan, "Particle Swarm Optimization (PSO) Tuning of PID Control on DC Motor," *International Journal of Robotics and Control Systems*, vol. 2, no. 2, pp. 435–447, Jul. 2022, doi: 10.31763/IJRC.S.V2I2.476.
22. A. Murad, O. Bayat, and H. M. Marhoon, "Implementation of rover tank firefighting robot for closed areas based on arduino microcontroller," *Indonesian Journal of Electrical Engineering and Computer Science*, vol. 21, no. 1, pp. 56-63, 2021.
23. A. A. Zaidan, B. B. Zaidan, M. Y. Qahtan, O. S. Albahri, A. S. Albahri, M. Alaa, and C. K. Lim, "A survey on communication components for IoT-based technologies in smart homes," *Telecommunication Systems*, vol. 69, no. 1, pp. 1-25, 2018.
24. T. K. Hui, R. S. Sherratt, and D. D. Sánchez, "Major requirements for building Smart Homes in Smart Cities based on Internet of Things technologies," *Future Generation Computer Systems*, vol. 76, pp. 358- 369, 2017.
25. M. Murad, O. Bayat, and H. M. Marhoon, "Design and implementation of a smart home system with two levels of security based on IoT technology," *Indonesian Journal of Electrical Engineering and Computer Science*, vol. 21, no. 1, pp. 546-557, 2021.
26. Q. I. Sarhan, "Arduino Based Smart Home Warning System," 2020 IEEE 6th International Conference on Control Science and Systems Engineering (ICCSSE), 2020, pp. 201-206.
27. A. S, N. Jayaram and J. A, "Desktop based Smart Voice Assistant using Python Language Integrated with Arduino," 2022 6th International Conference on Intelligent Computing and Control Systems (ICICCS), 2022, pp. 374-379.
28. S. A. Devi, M. S. Ram, K. Ranganarayana, D. B. Rao and V. Rachapudi, "Smart Home System Using Voice Command with Integration of ESP8266," 2022 International Conference on Applied Artificial Intelligence and Computing (ICAAIC), 2022, pp. 1535- 1539.
29. G. V. Ganesh, A. N. Reddy, A. S. S. V. Reddy and N. V. P. Chowdary, "Wireless Biometric Lock Using Arduino with the IoT," 2022 2nd International Conference on Artificial Intelligence and Signal Processing (AISP), 2022, pp. 1-6.
30. B. Shravani, K. Vyshnavi, R. S. Charan Reddy, R. U. Bhargavi, and S. Praveena, "Smart home automation and security using raspberry module," *International Journal of IoT*, vol. 1, no. 1, pp. 1-7, Feb 2022.
31. M. Hasan, T. I. Talukder, F. T. Z. Saima, M. N. U. Joy, A. Das and M. N. H. Sheham, "Smart Home Automation System Powered by Renewable Energy," 2022 IEEE International Conference on Distributed Computing and Electrical Circuits and Electronics (ICDCECE), 2022, pp. 1-7.
32. N. Mahesh, G. S. Deepak Prasath, E. Divyadharshini and V. Gokul, "Smart Faucet with Automatic Door Control System," 2022 Second International Conference on Artificial Intelligence and Smart Energy (ICAIS), 2022, pp. 1714-1719.
33. V. S. Gunge, and P. S. Yalagi, "Smart home automation: a literature review," *International Journal of Computer Applications*, vol. 975, pp. 8887-8891, 2016.
34. C. Stolojescu-Crisan, C. Crisan, and B. P. Butunoi, "An IoT-based smart home automation system," *Sensors*, vol. 21, no. 11, pp. 3784, 2021.
35. T. Alam, A. A. Salem, A. O. Alsharif, and A. M. Alhejaili, "Smart home automation towards the development of smart cities," *APTİKOM Journal on Computer Science and Information Technologies*, vol. 5, no. 1, pp. 152-159, 2020.
36. B. B. Gupta, and M. Quamara, "An overview of Internet of Things (IoT): Architectural aspects, challenges, and protocols," *Concurrency and Computation: Practice and Experience*, vol. 32, no. 21, pp. e4946, 2020.
37. J. Chandramohan, R. Nagarajan, K. Satheeshkumar, N. Ajithkumar, P. A. Gopinath, and S. Ranjithkumar, "Intelligent smart home automation and security system using Arduino and Wi-fi," *International Journal of Engineering and Computer Science (IJECS)*, vol. 6, no. 3, pp. 20694-20698, 2017.
38. A. W. L. Yao and H. C. Chen, "An Intelligent Color Image Recognition and Mobile Control System for Robotic Arm," *International Journal of Robotics and Control Systems*, vol. 2, no. 1, pp. 97–104, Feb. 2022.
39. W. A. Jabbar, T. K. Kian, R. M. Ramli, S. N. Zubir, N. S. Zamrizaman, M. Balfaqih, and S. Alharbi, "Design and fabrication of smart home with internet of things enabled automation system," *IEEE access*, vol. 7, pp. 144059-144074, 2019.
40. H. Yar, A. S. Imran, Z. A. Khan, M. Sajjad, and Z. Kastrati, "Towards smart home automation using IoT-enabled edge-computing paradigm," *Sensors*, vol. 21, no. 14, pp. 4932, 2021.

41. S. K. A. Shah and W. Mahmood, "Smart home automation using IOT and its low-cost implementation," *International Journal of Engineering and Manufacturing (IJEM)*, vol. 10, no. 5, pp. 28-36, 2020.
42. J. Walzberg, T. Dandres, N. Merveille, M. Cheriet, and R. Samson, "Should we fear the rebound effect in smart homes?," *Renewable and Sustainable Energy Reviews*, vol. 125, p. 109798, 2020.
43. O. K. Mohammed, O. Bayat, and H. M. Marhoon, "Design and implementation of integrated security and safety system based on internet of things," *International Journal of Engineering & Technology*, vol. 7, no. 4, pp. 5705-5711, 2018.
44. M. T. A. Mujitomo, H. Santoso, L. Widyawati, and D. Priyanto, "Home Security Voice Notification System with Arduino Sensor, PIR based SMS Gateway," *International Journal of Engineering and Computer Science Applications (IJECSA)*, vol. 1, no. 1, pp. 1-8, 2022.
45. Y. Astuti, Z. Zulfahri, E. Erianti, D. Damrah, P. Pitnawati, and Rosmawati, R., "Development of interactive learning media for low and overhead passing techniques in volleyball based on android technology using MIT app inventor," *Linguistics and Culture Review*, vol. 6, pp. 213-220, 2022.
46. A. Top and M. Gökbulut, "Android Application Design with MIT App Inventor for Bluetooth Based Mobile Robot Control," *Wireless Personal Communications*, pp. 1-27, 2022.
47. M. H. H. Rosman, R. Ghazali, G. P. Derai, H. I. Jaafar, C. C. Soon, D. Hanafi, and Z. Has, "Real-Time Underground Plastic Pipeline Water Leakage Detection and Monitoring System," *International Journal of Robotics and Control Systems*, vol. 2, no. 2, pp. 424-434, Jun. 2022, doi: 10.31763/IJRCS.V2I2.582.
48. M. A. Al Rakib, M. M. Rahman, M. S. Rana, M. S. Islam, and F. I. Abbas, "GSM based home safety and security system," *European Journal of Engineering and Technology Research*, vol. 6, no. 6, pp. 69-73, 2021.
49. A. Sarah, T. Ghozali, G. Giano, M. Mulyadi, S. Octaviani, and A. Hikmaturokhman, "Learning IoT: Basic Experiments of Home Automation using ESP8266, Arduino and XBee," in *Proceedings 2020 IEEE International Conference on Smart Internet of Things, Smart IoT 2020*, Aug. 2020, pp. 290-294.
50. A. I. Abdulla, A. S. Abdulraheem, A. A. Salih, M. A. Sadeeq, A. J. Ahmed, B. M. Ferzor, and S. I. Mohammed, "Internet of things and smart home security," *Technol. Rep. Kansai Univ*, vol. 62, no. 5, pp. 2465-2476, 2020.
51. M. A. Baballe, U. Y. Magashi, B. I. Garko, A. A. Umar, Y. R. Magaji, M. Surajo, "Automatic Gas Leakage Monitoring System Using Mq-5 Sensor", *Review of Computer Engineering Research*, Vol. 8, No. 2, pp. 64-75, DOI: 10.18488/journal.76.2021.82.64.75, 2021.
52. M. A. Baballe, M. I. Bello, A. S. Mahmoud, "Comparative Study of Gas Alarm Detection System", *Journal of Telecommunication Control and Intelligent System (JTICIS)*, Vol. 1, No. 2, pp. 65-72, 2021.
53. M. A. Baballe, M. I. Bello, "Gas Leakage Detection System with Alarming System", *Review of Computer Engineering Research*, Vol. 9, No. 1, pp. 30-43, DOI: 10.18488/76.v9i1.2984, 2022.
54. M. B. Ahmad et. al., "Need for Security Alarm System Installation and their Challenges Faced", *International Journal of New Computer Architectures and their Applications (IJNCAA)* vol. 9, no. 3, pp. 68-76, The Society of Digital Information and Wireless Communications, 2019.
55. M. B. Ahmad, A. A. Abdullahi, A. S. Muhammad, Y. B. Saleh, U. B. Usman, "The Various Types of sensors used in the Security Alarm system", *International Journal of New Computer Architectures and their Applications (IJNCAA)* vol. 9, no. 2 pp. 50-59, The Society of Digital Information and Wireless Communications, 2019.
56. A. A. Sahrab, H. M. Marhoon, "Design and Fabrication of a Low-Cost System for Smart Home Applications", *Journal of Robotics and Control (JRC)* Volume 3, Issue 4, pp. 409-414, July 2022.
57. M. A. Baballe, M. I. Bello, A. A. Umar, D. Bello, S. A. Muhammad, S. R. Dan Sharif, "Visitors Counter with Gate Control and Automatic Room Light Controller (ON/OFF)", *Global Journal of Research in Engineering & Computer Sciences*, Vol. 02, Issue 02, pp. 32-40, Journal homepage: <https://gjrpublication.com/journals/>, 2022.
58. M. B. Ahmad, F. A. Nababa, "A comparative study on radio frequency identification system and its various applications", *International Journal of Advances in Applied Sciences (IJAAS)*, Vol. 10, No. 4, pp. 392~398, DOI: 10.11591/ijaas.v10.i4.pp392-398, December 2021.
59. M. A. Baballe, "A Study on the Components used in RFID System and its Challenges", *Global Journal of Research in Engineering & Computer Sciences*, Vol. 01, Issue 01, pp. 21-27, Journal homepage: <https://gjrpublication.com/journals/>, | Sep-Oct | 2021.
60. M. A. Baballe, M. I. Bello, B. A. Imam, A. T. Sule, A. S. Muhammad, "Implementation of Security Alarm using Arduino with P.I.R Motion Sensor and GSM Module", *Artificial & Computational Intelligence*, https://acors.org/ijacoi/VOL2_ISSUE2_8.pdf, pp. 1-7, July 2021.
61. M. B. Ahmad, "A review on the Impact of Solar Power Energy", *Global Journal of Research in Engineering & Computer Sciences* Vol. 01, Issue 01, pp. 1-7, <https://gjrpublication.com/journals/>, Sep-Oct | 2021.
62. M. B. Ahmad, A. S. Muhammad, H. A. Hussain, A. H. Muhammad, A. M. Sani, "Review on Impact of Installing the Solar Tracking System Its Challenges and Types", *Artificial & Computational Intelligence*, pp. 1-7, https://acors.org/ijacoi/VOL1_ISSUE5_08.pdf, December 2020.
63. M. Çavaş, M. B. Ahmad, "A Review Advancement of Security Alarm System using Internet of Things (IoT)", *International Journal of New Computer Architectures and their Applications (IJNCAA)*, vol. 9, no. 2, pp. 38-49, The Society of Digital Information and Wireless Communications, 2019.
64. M. B. Ahmad, M. I. Bello, A. S. Muhammad, A. B. Imam, "Design and Simulation of Crossed Walls Security Detection System", *International Journal of New Computer Architectures and their Applications (IJNCAA)*, vol. 11, no. 1, pp. 10-21, The Society of Digital Information and Wireless Communications, 2021.
65. M. A. Baballe, "DETECTION OF CROSSED WALLS SECURITY ALARM SYSTEM AGAINST INVASION", *Review of Computer Engineering Research*, Vol. 8, No. 1, pp. 14-26, DOI: 10.18488/journal.76.2021.81.14.26, 2021.
66. M. Çavaş, M. B. Ahmad, "Design and Simulation of Personal Computer Base Walls Crossed Security System Against Intrusion Using PIC Microcontroller", *International Journal of Engineering Science Invention (IJESI)*, www.ijesi.org, Vol. 8, Issue 03, pp. 59-74, March 2019.

67. M. Çavaş, M. B. Ahmad, “Design and Simulation of Four Walls Crossed Security System against Intrusion Using Pic Microcontroller”, *American Journal of Engineering Research (AJER)*, Vol 7, Issue 12, pp-233-244, www.ajer.org, 2018.
68. M. B. Ahmad, N. Varol, S. Azeez, “A Review of Home Alarm Systems against Intrusion”, *TBD 35 National Informatics Congress*, pp. 193-196, 2018.
69. M. A. Baballe, M. I. Bello, A. A. Umar, A. K. Shehu, D. Bello, F. T. Abdullahi, “A Look at the Different Types of Servo Motors and their Applications”, *Sarcouncil Journal of Engineering and Computer Sciences*, Vol. 1, Issue 02, pp. 4-9, 2022.
70. M. A. Baballe et. Al. “The Impact of the Energy Management and Monitoring System”, *Global Journal of Research in Engineering & Computer Sciences*, Volume 02| Issue 04 pp. 14-18, Journal homepage: <https://gjrppublication.com/gjrecs/>, | July-Aug. | 2022.
71. https://www.google.com/search?q=smart+home+control+and+management+system+design+and+development+future+directions&scas_esv=17b6ad23b7736742&xsrf=AE3TifOiwM48czkyRWvIOkvCGjnoN8ocEQ%3A1761151927694&ei=twv5aK6HKqzWhbIP1pGP2QY&ved=0ahUKEwjvq6YoriQAxUsa0EAHdbII2sQ4dUDCBE&uact=5&oq=smart+home+control+and+management+system+design+and+development+future+directions&gs_lp=Egxnd3Mtd2l6LXNlcniAUXNtYXJ0IGhvbWUgY29udHJvbCBhbmQgbWVudCBzeXN0ZW0gZGVzaWduIGFuZCBkZXZlbG9wbWVudCBmdXR1cmUgZGlyZWNoaW9uc0jzXVD2CViuWHABeACQAQCYAbgEoAHEWkoBCjltOC4xOS41LjG4AQPIAQD4AQGYAgOgAqcFwgIKEAAySAMY1gQYR8ICBBAjGCeYAwClBgGQBgiSBwUxLjMtMqAHzk6yBwMzLTK4B5oFwgcFMi0xLjLiBxc&scient=gws-wiz-serp
72. I. A. Ibrahim, Abdurrahman I. A., & Muhammad A. B. “Artificial Intelligence-Enhanced Wireless Medical Alert Systems: Overcoming Challenges, Mitigating Effects, and Addressing Limitations”, In *Global Journal of Research in Engineering & Computer Sciences* Vol. 5, Number 3, pp. 53–58, 2025, <https://doi.org/10.5281/zenodo.15521486>.
73. I. A. Ibrahim, M. A. Baballe, “Essential Elements Required for a Successful AI Application in the Healthcare Industry”, In *Global Journal of Research in Engineering & Computer Sciences*, Vol. 4, Number 5, pp. 46–51, 2024, <https://doi.org/10.5281/zenodo.13755067>.
74. I. A. Ibrahim, M. A. Baballe, “Bidirectional People Counters as a Catalyst for Smart Cities in the Technological Singularity Era”, Volume 11, Issue 10, *JETIR* October 2024.
75. I. A. Ibrahim, M. A. Baballe, “Developing a User-Friendly Smart Blind Stick for Visually Impaired Individuals in the Digital Era”, *JETIR*, Volume 11, Issue 9, September 2024.
76. Isa A.I., & Muhammad A. B. “Overcoming Facility Management Challenges using IoT-Based Smart Energy Management Systems”, In *Global Journal of Research in Engineering & Computer Sciences* Vol. 4, Number 5, pp. 95–99, 2024, <https://doi.org/10.5281/zenodo.13823585>.
77. M. A. Baballe, et. al., “Design and Development of Control and Management Systems for Smart Homes”, *International Journal on Recent Technologies in Mechanical and Electrical Engineering*, 9(3), 136–152, 2024, <https://doi.org/10.17762/ijrmee.v9i3.384>.
78. I. A. Ibrahim, et al., “Smart Home Control and Management System Design and Development: Future Directions”, *JETIR* Volume 12, Issue 10, October 2025.